

ITEM NO.	PART NUMBER	DESCRIPTION	QTY.
1	3-897-10080	MOUNTING BOLT, 10x1.5, 80mm	3
2	3-891-308P	FULL OEM JAW REPLACEMENT SET, 8IN, 3-JAW	3
3	3-809-906P	FITTING, GREASE	1
4	C-CK8-BY3JFM	CHUCK BODY, 8IN	1
5	3-886-308P	PINION FOR 8in SCROLL CHUCK	3
6	3-889-008P	WRENCH FOR 6IN & 8IN SCROLL CHUCK	1
7	3-887-308P	SCROLL PLATE FOR 8in CHUCK	1
8	3-888-910P	PINION SCREW FOR 8, 10 OR 12in CHUCK	3
9	C-CK8-COVER	PLATE, COVER, MACHINED	1
10	3-899-310P	SHCS, M8x1.25X16	3

-CLICK ON LINK BELOW FOR REPLACEMENT PARTS-

[WWW.TOOLMEX.COM](http://WWW.TOOLMEX.COM)

SELLING UNIT: EACH  
 CHUCK TYPE: SCROLL  
 CHUCK SIZE: 8IN  
 BODY MATERIAL: FORGED STEEL  
 NUMBER OF JAWS: 3  
 JAW TYPE: 2 PIECES  
 WEIGHT: 39 LBS  
 MOUNT TYPE: FRONT  
 GRIPPING FORCE: 3700 daN  
 SPEED: 4000 RPM Max.

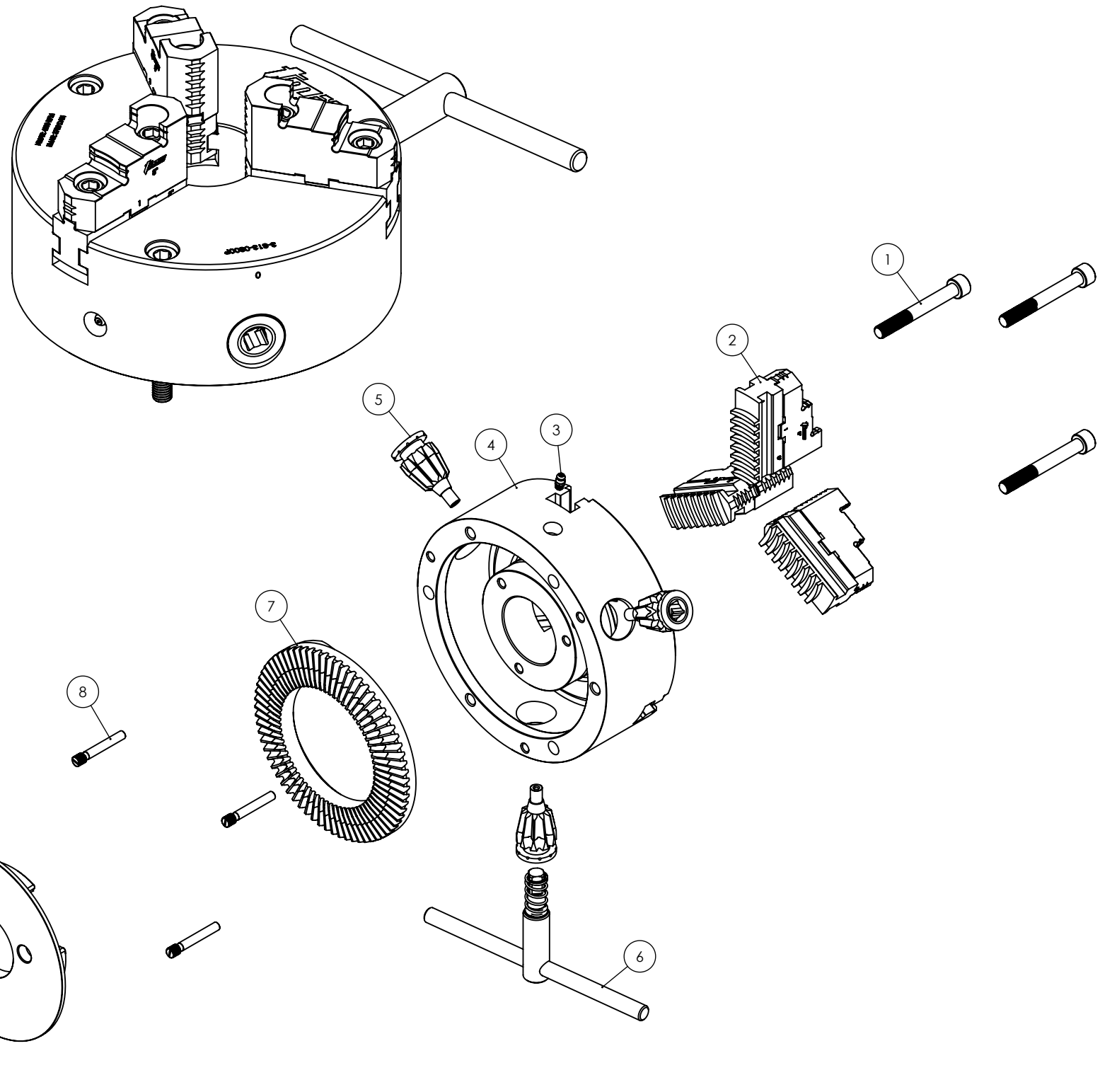

MATERIAL:	SEE BOM	NAME	T. THACH	DATE	10-23-2024
HARDNESS:	N/A	FINISH:	N/A	DRAWN	T. THACH
<u>CONTACT INFORMATION:</u> Toll Free 855-869-2425 Fax 508-653-5110 www.tmxtools.com 34 TALBOT ROAD NORTH BOROUGH, MA 01532 USA			ENG APPR.	T. THACH	10-23-2024
INTERPRET GEOMETRIC TOLERANCING PER: Y1999-2001			MFG APPR.		
 THIRD ANGLE PROJECTION			Q.A. APPR.		
CONFIDENTIAL THIS DRAWING AND THESE SPECIFICATIONS ARE THE SOLE PROPERTY OF TOOLMEX INDUSTRIAL SOLUTIONS, AND SHALL NOT BE REPRODUCED, OR COPIED IN PART OR AS A WHOLE WITHOUT THE EXPRESS WRITTEN PERMISSION OF TOOLMEX INDUSTRIAL SOLUTIONS IS PROHIBITED.			SALES APPR.		
<b>Tmx</b> ™ SOLE PROPERTY OF TOOLMEX INDUSTRIAL SOLUTIONS		TITLE 8IN PLAIN BACK FRONT MOUNT SCROLL CHUCK		SIZE <b>B</b>	
		DWG. NO. <b>3-813-0800P</b>		REV <b>A</b>	
UNITS IN MILLIMETER					
DO NOT SCALE DRAWING			SHEET 1 OF 3		

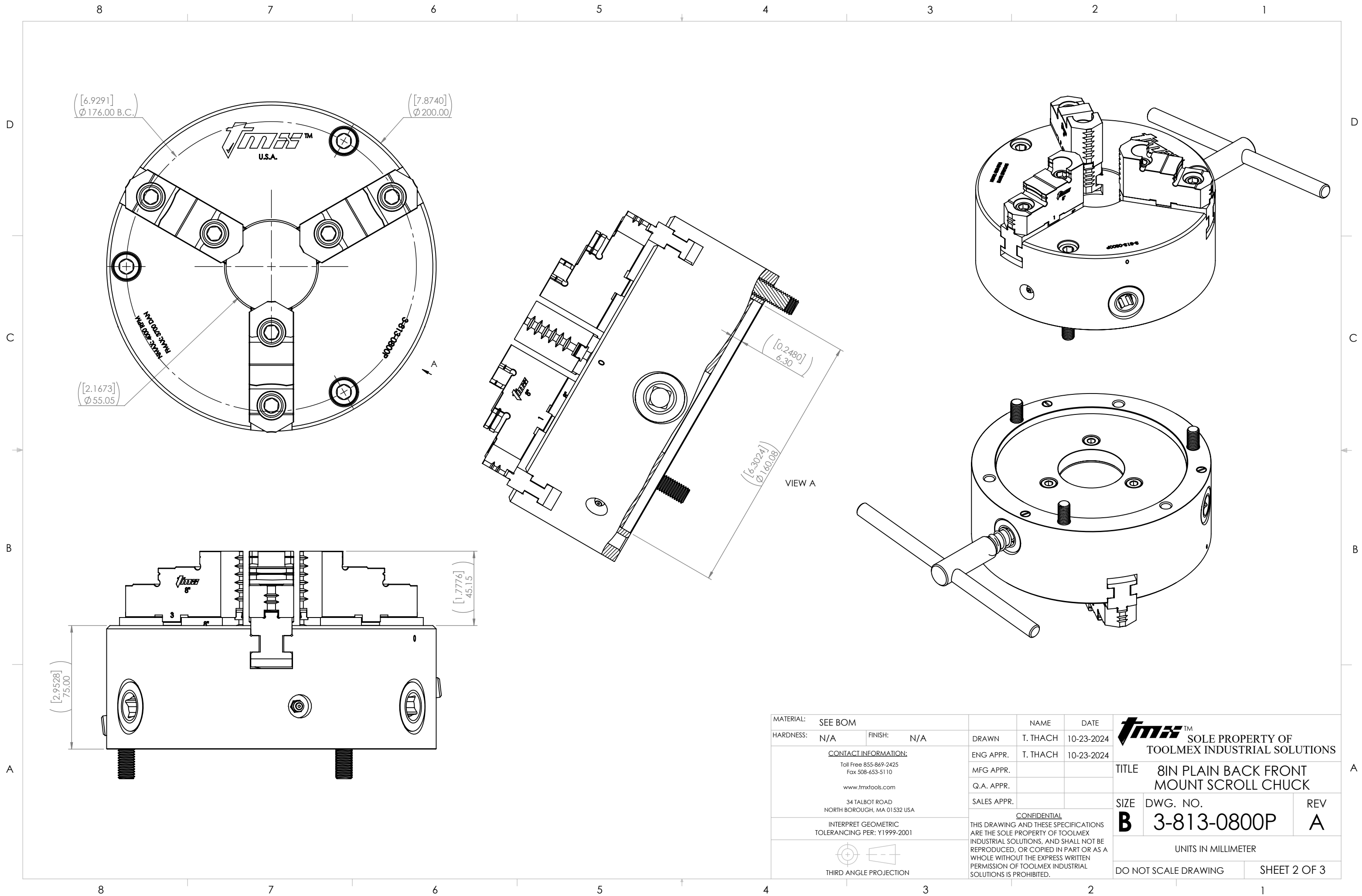

MATERIAL:	SEE BOM	NAME	T. THACH	DATE	10-23-2024
HARDNESS:	N/A	FINISH:	N/A	DRAWN	T. THACH
<p><b>CONTACT INFORMATION:</b>  Toll Free 855-869-2425  Fax 508-653-5110  www.tmxtools.com  34 TALBOT ROAD  NORTH BOROUGH, MA 01532 USA</p>			ENG APPR.	T. THACH	10-23-2024
			MFG APPR.		
			Q.A. APPR.		
			SALES APPR.		
<p>INTERPRET GEOMETRIC TOLERANCING PER: Y1999-2001</p>			<p><b>CONFIDENTIAL</b>  THIS DRAWING AND THESE SPECIFICATIONS ARE THE SOLE PROPERTY OF TOOLMEX INDUSTRIAL SOLUTIONS, AND SHALL NOT BE REPRODUCED, OR COPIED IN PART OR AS A WHOLE WITHOUT THE EXPRESS WRITTEN PERMISSION OF TOOLMEX INDUSTRIAL SOLUTIONS IS PROHIBITED.</p>		
<p>THIRD ANGLE PROJECTION</p>			<p><b>SOLE PROPERTY OF TOOLMEX INDUSTRIAL SOLUTIONS</b></p>		
<p>TITLE</p>		<p>8IN PLAIN BACK FRONT MOUNT SCROLL CHUCK</p>		<p>REV</p>	
<p>SIZE</p>		<p>DWG. NO.</p>		<p>A</p>	
<p><b>B</b></p>		<p>3-813-0800P</p>		<p>UNITS IN MILLIMETER</p>	
<p>DO NOT SCALE DRAWING</p>		<p>SHEET 2 OF 3</p>			

8 7 6 5 4 3 2 1

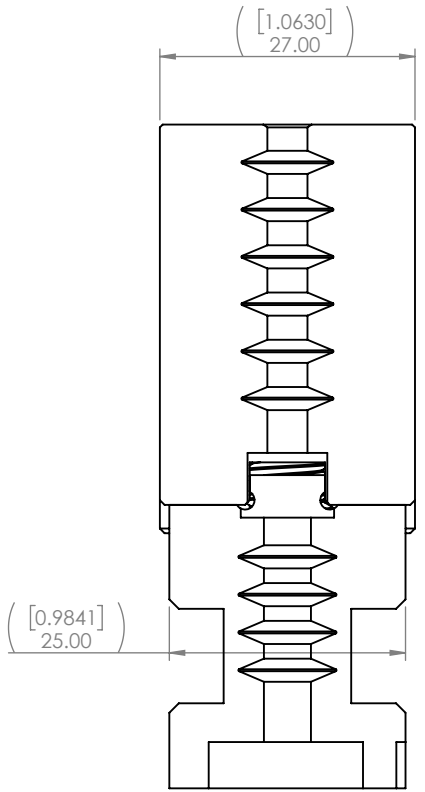
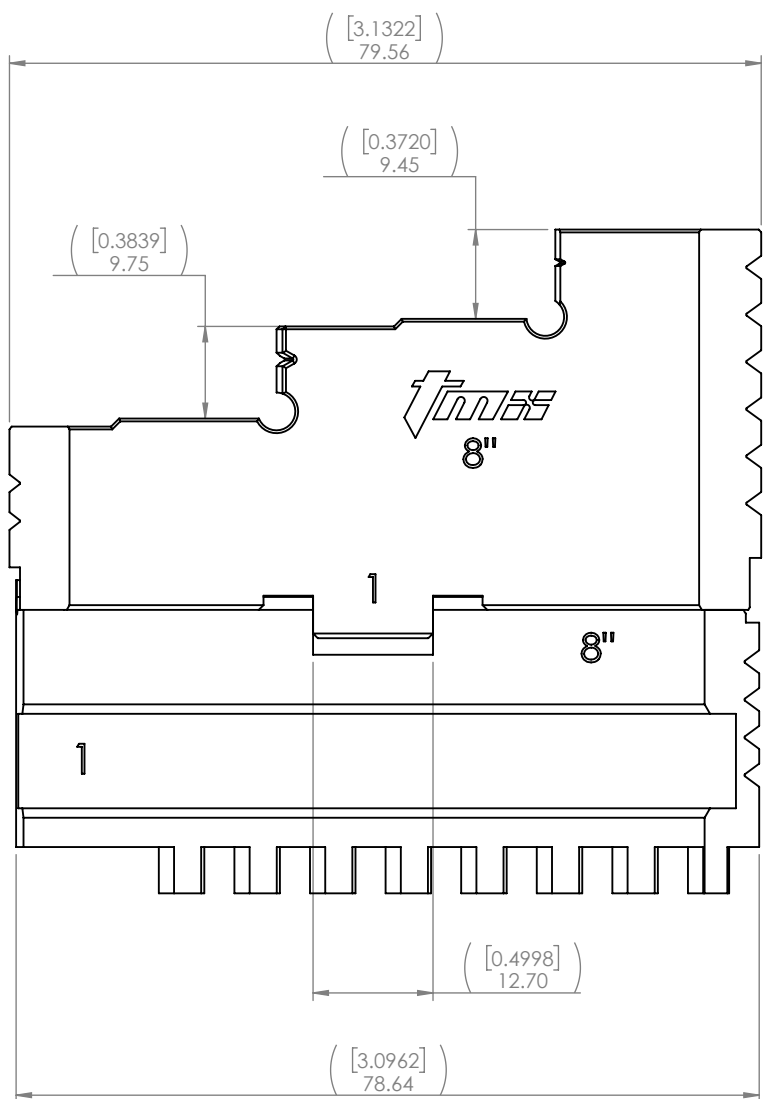
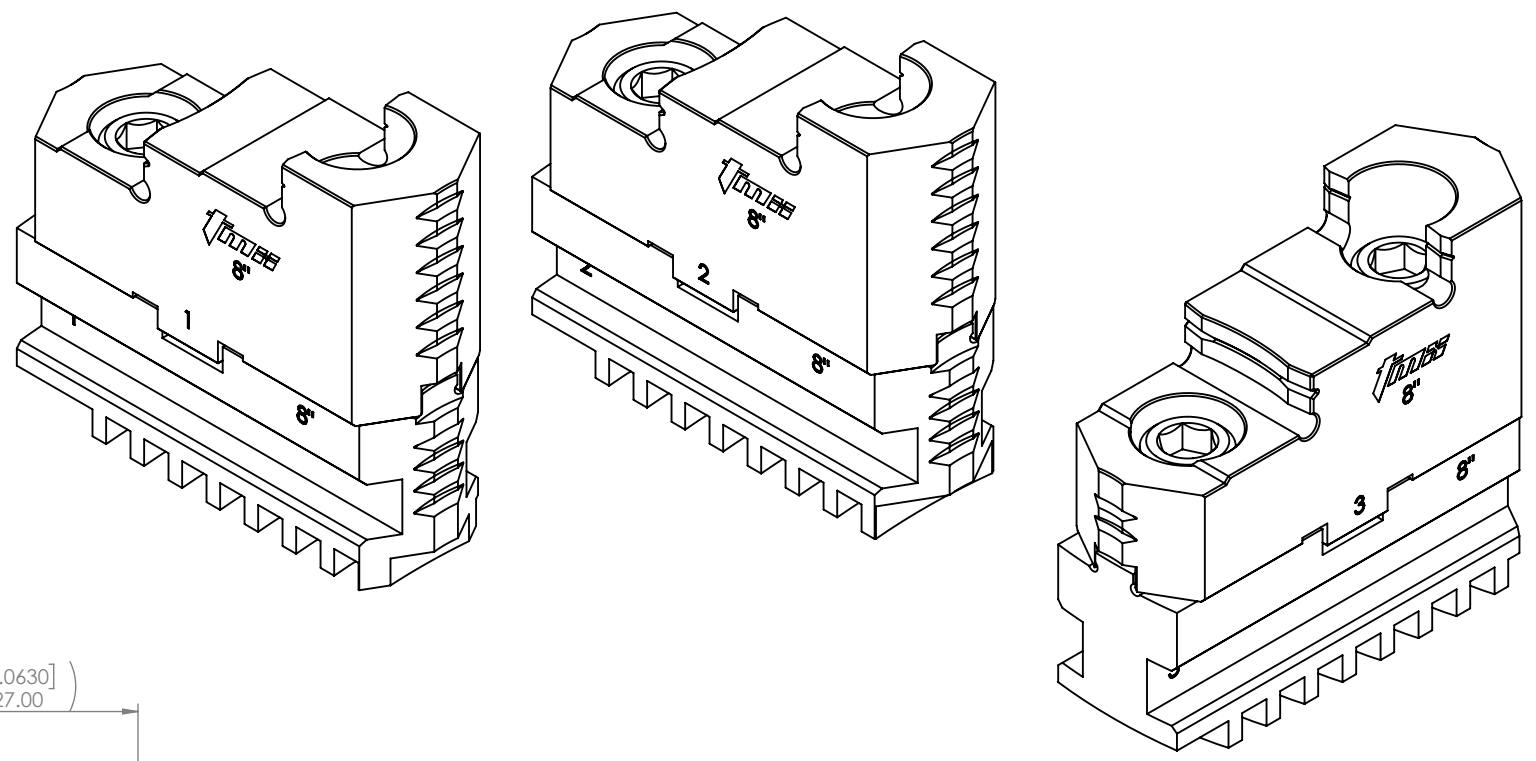
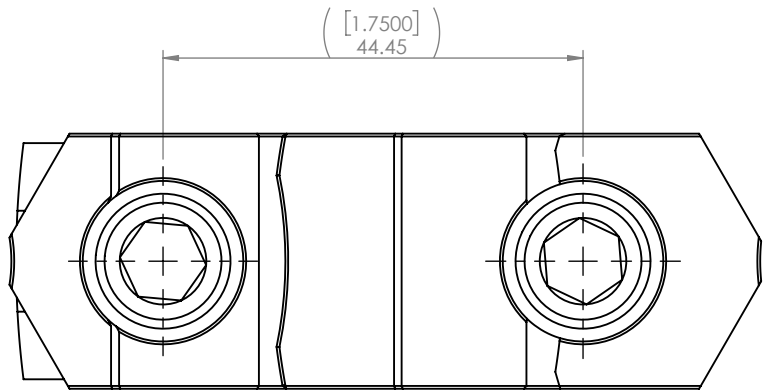

**-CLICK ON LINKS BELOW FOR REPLACEMENT PARTS-**  
[3-883-308P, HARD TOP JAWS, 6IN, 3-JAW 3 PC SET](#)  
[3-885-308P, HARD MASTER JAWS, 6IN, 3-JAW 3 PC SET](#)

D  
C  
B  
A

D  
C  
B  
A

MATERIAL:	SEE BOM	NAME	T. THACH	DATE	10-23-2024
HARDNESS:	N/A	FINISH:	N/A	DRAWN	T. THACH
<p><b>CONTACT INFORMATION:</b>                  Toll Free 855-869-2425                  Fax 508-653-5110                  www.tmxtools.com                  34 TALBOT ROAD                  NORTH BOROUGH, MA 01532 USA</p>			ENG APPR.	T. THACH	10-23-2024
			MFG APPR.		
			Q.A. APPR.		
			SALES APPR.		
<p>INTERPRET GEOMETRIC TOLERANCING PER: Y1999-2001</p>			<p><b>CONFIDENTIAL</b>                  THIS DRAWING AND THESE SPECIFICATIONS ARE THE SOLE PROPERTY OF TOOLMEX INDUSTRIAL SOLUTIONS, AND SHALL NOT BE REPRODUCED, OR COPIED IN PART OR AS A WHOLE WITHOUT THE EXPRESS WRITTEN PERMISSION OF TOOLMEX INDUSTRIAL SOLUTIONS IS PROHIBITED.</p>		
<p>THIRD ANGLE PROJECTION</p>			<p>SOLE PROPERTY OF                  TOOLMEX INDUSTRIAL SOLUTIONS</p>		
<p>TITLE                  8IN PLAIN BACK FRONT MOUNT SCROLL CHUCK</p>		<p>SIZE  <b>B</b></p>	<p>DWG. NO.                  3-813-0800P</p>	<p>REV                  A</p>	
<p>UNITS IN MILLIMETER</p>			<p>DO NOT SCALE DRAWING</p>		
			<p>SHEET 3 OF 3</p>		

8 7 6 5 4 3 2 1